

◆ Features

- Strip Resonator Crystal
- Resistance Weld Seal
- AT-cut or BT-cut
- Excellent Aging

◆ Options

- Insulating Pad
- 3rd Lead (Bottom)
- Custom Lead length
- Tape or Vinyl-pack
- 3.5mm Height Max

Part Numbering system is in Page 29, [click here](#)

◆ Dimension(mm)

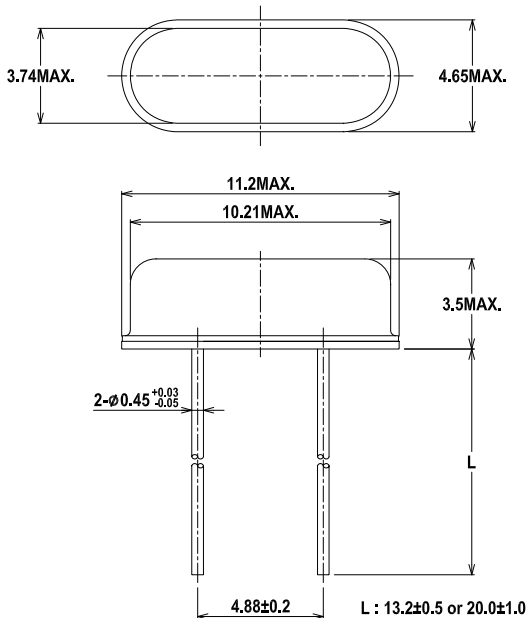

◆ Standard Specification

(Nominal frequency referenced to frequency at 25 °C ±2 °C)

PARAMETERS	M9S
Frequency Range	3.2680MHz ~ 75.0000MHz
Frequency Tolerance @ 25°C±3°C	± 30ppm (Typ.)
Stability Over Operating Temperature Range (in reference to 25°C)	± 50ppm (Typ.)
Operating Temperature Range	-20°C +70°C // -40°C +85°C
Equivalent Series Resistance (ESR)	*See Table
Shunt Capacitance	7pF maximum
Load Capacitance	10pF ~ Series
Drive Level	25µW (1000µW max.)
Aging per year	±5ppm
Insulation Resistance	500 Megaohms Minimum at 100V _{DC}
•Tighter tolerances, stabilities & operating temperature ranges available	

◆ Nominal Frequency & ESR

Frequency Range (MHz)	Mode	Max. ESR (Ω)	Frequency Range (MHz)	Mode	Max. ESR (Ω)
3.268000 ~ 3.999999	Fundamental	200	14.000000 ~ 32.000000	Fundamental	50
4.000000 ~ 4.999999		150	28.224000 ~ 29.999999	3rd Overtone	100
5.000000 ~ 7.299999		120	30.000000 ~ 75.000000		80
7.300000 ~ 9.999999		80	29.000000 ~ 50.000000	BT-cut	50
10.000000 ~ 13.999999		60			

MDX codification Quartz (Part Numbering System)

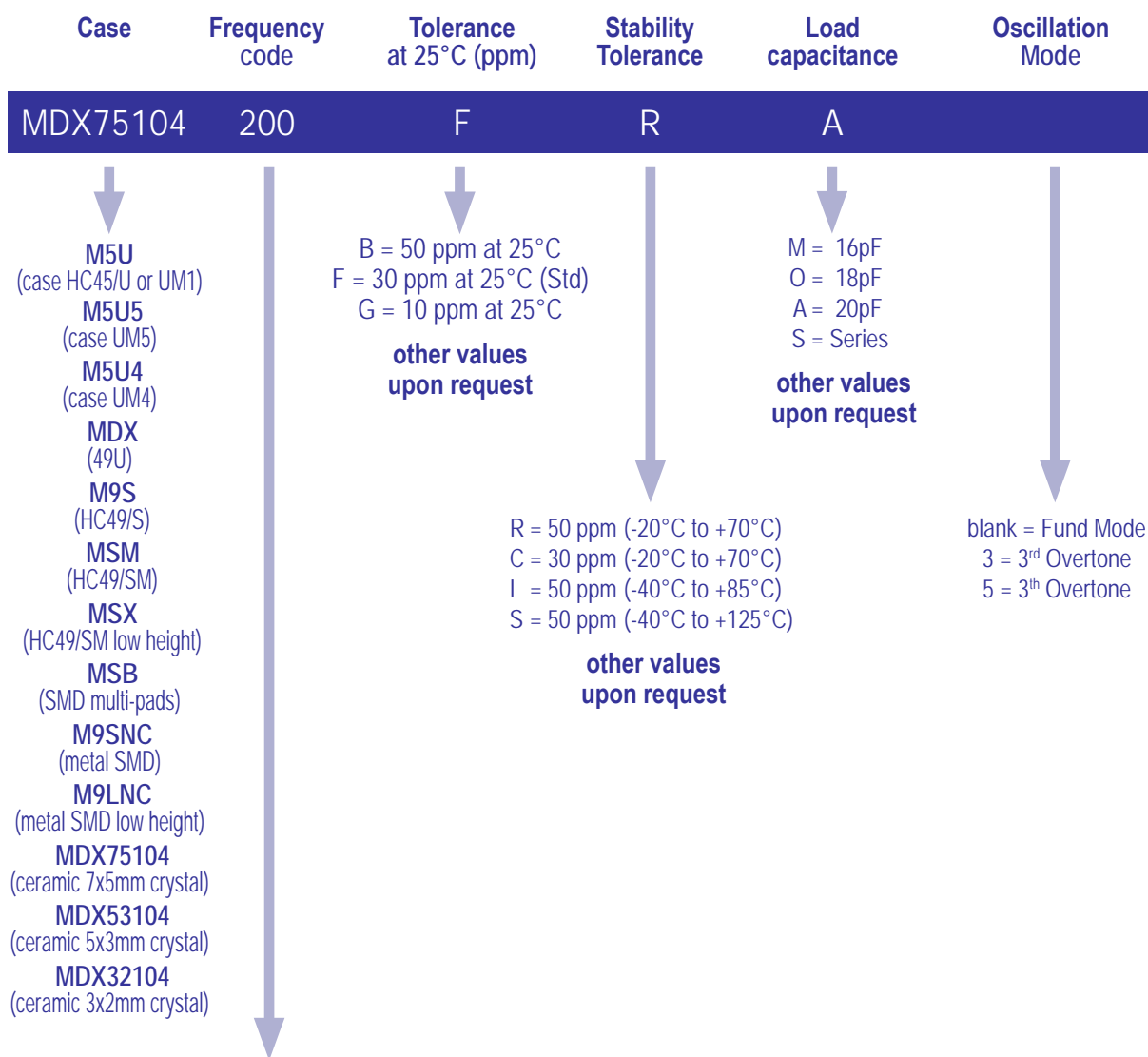

Fréquence en MHz	Codes Fréquences	SR Max.	Fréquence en MHz	Codes Fréquences	SR Max.	Fréquence en MHz	Codes Fréquences	SR Max.
3.579545	035	200	10.000000	100	60	24.000000	240	50
3.686400	037	200	10.738635	107	60	24.576000	245	50
4.000000	040	150	11.000000	110	60	25.000000	250	50
4.096000	0409	150	11.059200	111	60	26.800000	268	120 / 3 OT
4.194304	041	150	12.000000	120	60	* 26.800000	268B	50
4.433619	044	150	12.288000	122	60	27.000000	270	80 / 3 OT
4.915200	049	150	12.500000	125	60	28.636360	286	80 / 3OT
5.000000	050	120	13.000000	130	60	28.800000	288B	50
5.068800	051	120	13.500000	135	60	30.000000	300	80 / 3 OT
5.200000	052	120	14.318180	143	50	32.000000	320	80 / 3 OT
6.000000	060	120	14.745600	147	50	* 32.000000	320B	50
6.144000	061	120	15.000000	150	50	33.000000	330	80 / 3 OT
6.553600	065	120	16.000000	160	50	* 33.000000	330B	50
7.000000	070	120	16.384000	163	50	* 33.868800	338B	50
7.159090	071	120	18.000000	180	50	* 36.000000	360B	50
7.200000	072	120	18.432000	184	50	40.000000	400	80 / 3 OT
7.372800	073	80	18.867000	188	50	* 40.000000	400B	50
7.680000	077	80	19.660800	196	50	48.000000	480	80 / 3 OT
8.000000	080	80	20.000000	200	50	50.000000	500	80 / 3 OT
9.216000	092	80	22.000000	220	50	60.000000	600	80 / 3 OT
9.830400	098	80	22.118400	221	50	64.000000	640	80 / 3 OT
						66.000000	660	80 / 3 OT