

Challenging the world with advanced material products

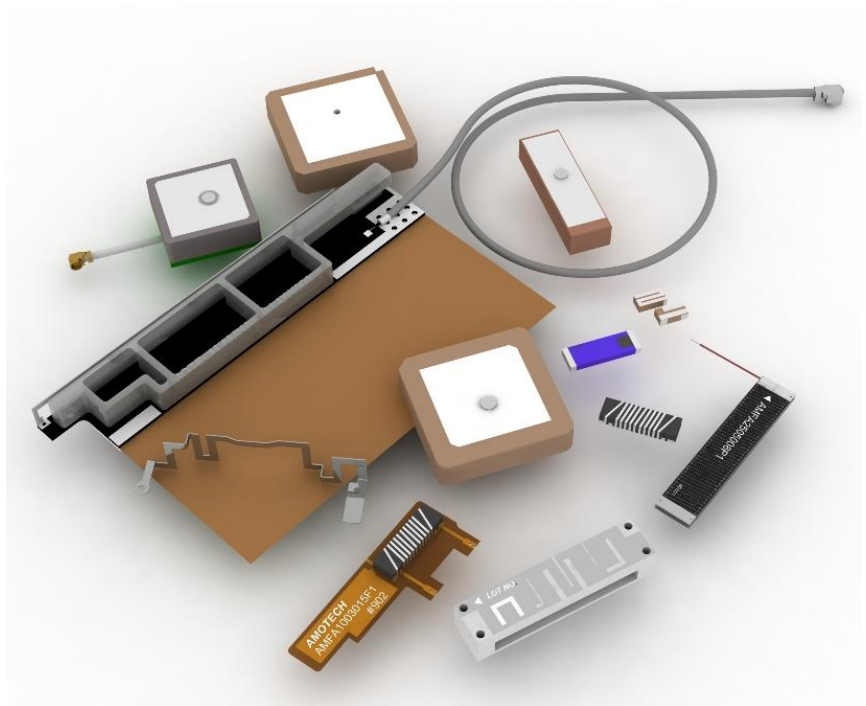

# Leading antenna solution provider

*The Most Reliable Antenna*



[www.amotech.co.kr](http://www.amotech.co.kr)

# GPS Antenna

## Ceramic patch-Pin type



### Feature & Specification

- High Efficiency and high directivity
- Compact size and low profile fit to small device
- Pin type antenna is relatively stable to change in temperature and excellent circular polarization

Type	Part No.	Size [mm]	Frequency [MHz]	Peak Gain [dBic]	Beam Pattern	Ground Plane [mm]
	A10-45AC753-STD10	10x10x4T	1575	-4.0 Typ.	RHCP	10x10 sq.
	A12-2D79753-STD12	12x12x2T	1575	-4.5 Typ.	RHCP	12x12 sq.
	A20-4165753-STD60	20x20x4T	1575	4.0 Typ.	RHCP	60x60 sq.
	B25-2D02753-STD70	25x25x2T	1575	4.0 Typ.	RHCP	70x70 sq.
	B35-3556753-STD70	35x35x3T	1575.42	5.0 Typ.	RHCP	70x70 sq.
	YDRA-A15-1575	15x15x4T	1575	4.0 Typ.	RHCP	30x30 sq.
	YDRA-A18-1575	18x18x4T	1575	3.0 Typ.	RHCP	50x50 sq.
	YDRA-A25-1575	25x25x4T	1575	5.0 Typ.	RHCP	70x70 sq.
	A2513-4502753-INT4	25x13x4T	1575.42	1.0 Typ.	LP	52x13 sq.
	A2006-453B753-STD2006	20x6x4T	1575	0.65 Typ.	LP	20x6 sq.

Note: Customized design available & Matching Service provided  
 SDARS frequency available with 25x25, 20x20 & 18x18 size

# GPS Antenna

## Ceramic patch-SMD Type



### Feature & Specification

- Easy mount to surface
- High Efficiency and high directivity
- Compact size and low profile fit to small device

Type	Part No.	Size [mm]	Frequency [MHz]	Peak Gain [dBic]	Beam Pattern	Ground Plane [mm]
	A10-48A0753-STD10	10x10x4T	1575.42	-4.0 Typ.	RHCP	10x10 sq
	A12-2870753-STD12	12x12x2T	1575	-3.3 Typ.	RHCP	12x12 sq
	B18-4830933-STD70	18x18x4T	1593	4.0 Typ.	RHCP	70x70 sq
	H25-4800863-STD70	25x25x4T	1586	4.0 Typ.	RHCP	70x70 sq

Note: Customized design available & Matching service provided

### Application

- Portable Navigation Device
- PDA
- Lap Top
- Digital Camera
- Automotive
- Personal Tracker



# GPS Antenna

## GPS & Glonass



### Feature & Specification

- High Efficiency and high directivity
- Compact size and low profile

Type	Part No.	Size [mm]	Frequency [MHz]	RL [dB]	Gain [dBic]	Beam Pattern
	A25-4102023-STD70	25x25x4T	1602±3.0	15 min.	5.0 Typ.	RHCP
	A25-4102920-AMT02	25x25x4T	1570~1613	7 min.	3.5 Typ.	RHCP
	B35-3556920-AMT03	35x35x3T	1570~1613	7 min.	4.0 Typ.	RHCP

Note: Customized design available & Matching service provided  
Both pin and SMD type available



# GPS Antenna

## Ceramic chip



### Feature & Specification

- High Efficiency in the limited space
- Small fill-cut area

Type	Part No.	Size [mm]	Frequency [MHz]	Avg. Gain	VSWR	Impedance
	AMAN1003040	10.0x3.0x4.0	1575.42	-3 dBi min.	2.0 : 1 max.	50 Ω
	AMAN1603025	16.0x3.0x2.5	1575.42	-2.5 dBi min.	2.0 : 1 max.	50 Ω

Note: Customized design available & Matching service provided

### Application

- Portable Navigation Device
- PDA
- Lap Top
- Digital Camera
- Mobile Phone : A-GPS





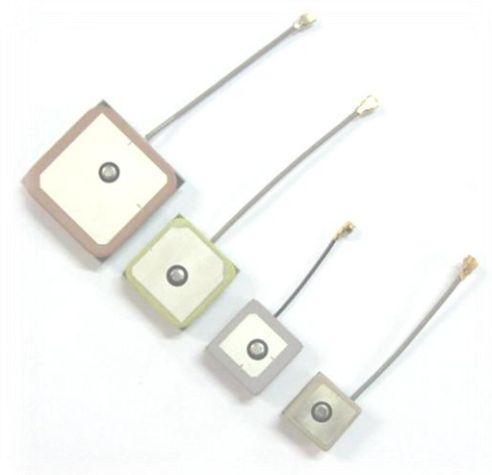



# GPS Antenna

## Active antenna



### Feature & Specification

- Small size & low profile
- Low noise
- Customized LNA gain available

Type	Part No.	Width [mm]	Height [mm]	Frequency [MHz]	Beam Pattern	Gain [dB]	Output VSWR
	AGA121202-S0-A2	12x12±1.0	5.2 max.	1575.42	RHCP	25 typ.	1.5 : 1 typ.
	AGA121204-S0-A3	12x12±1.0	7.0 max.	1575.42	RHCP	27 typ.	1.5 : 1 typ.
	AGA131304-S0-A2	13x13±1.0	7.0 max.	1575.42	RHCP	19 typ.	1.5 : 1 typ.
	AGA151504-S0-A3	15x15±1.0	6.8 max.	1575.42	RHCP	19 typ.	1.5 : 1 typ.
	AGA181802-S0-A1	18x18±1.0	5.2 max.	1575.42	RHCP	27 typ.	1.5 : 1 typ.
	AGA181804-S0-A1	18x18±1.0	7.2 max.	1575.42	RHCP	27 typ.	1.5 : 1 typ.
	AGA252502-S0-A1	25x25±1.0	6.0 max.	1575.42	RHCP	27 typ.	1.5 : 1 typ.
	AGA252504-S0-A2	25x25±1.0	7.5 max.	1575.42	RHCP	25 typ.	1.5 : 1 typ.

Note: Customized design available

# 2.4GHz wireless Communication

## Multilayer ceramic chip



### Feature & Specification

- Wide bandwidth
- High efficiency in the limited space
- competitive price

Type	Part No.	Size [mm]	Frequency [GHz]	VSWR	Impedance	Beam Pattern
	ALA131C3	11.0x3.0x1.2	2.4~2.5	2.5 : 1 max.	50 Ω	Omni-directional
	ALA321C3	3.2x1.6x1.2	2.4~2.5	3.0 : 1 max.	50 Ω	Omni-directional
	ALA621C4	6.0x2.0x1.2	2.4~2.5	3.0 : 1 max.	50 Ω	Omni-directional
	ALA621C5	6.0x2.0x1.0	2.4~2.5	3.0 : 1 max.	50 Ω	Omni-directional
	ALA931C5	9.0x3.0x1.2	2.4~2.5	2.5 : 1 max.	50 Ω	Omni-directional
	ALA201510ST01	2.0x1.5x1.0	2.4~2.5	3.0 : 1 max.	50 Ω	Omni-directional

Note: Customized design available & Matching service provided

# 2.4GHz wireless Communication

## Multilayer ceramic chip

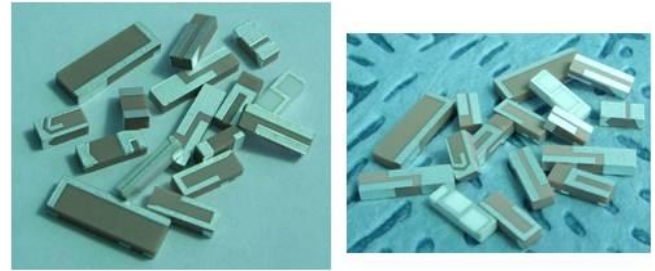

### Feature & Specification

- Small fill-cut area
- High efficiency in the limited space

Type	Part No.	Size [mm]	Frequency [GHz]	VSWR	Impedance	Beam Pattern
	AMAN201510ST01	2.0x1.5x1.0	2.4~2.5	3.0 : 1 max.	50 Ω	Omni-directional
	AMAN301512ST01	3.0x1.5x1.2	2.4~2.5	3.0 : 1 max.	50 Ω	Omni-directional
	AMAN402012ST01	4.0x2.0x1.2	2.4~2.5	3.0 : 1 max.	50 Ω	Omni-directional
	AMAN402012MS01	4.0x2.0x1.2	2.4~2.5	3.0 : 1 max.	50 Ω	Omni-directional
	AMAN802012MS01	8.0x2.0x1.2	2.4~2.5	2.5 : 1 max.	50 Ω	Omni-directional

Note: Customized design available & Matching service provided

# 2.4GHz wireless Communication

## FPCB Type

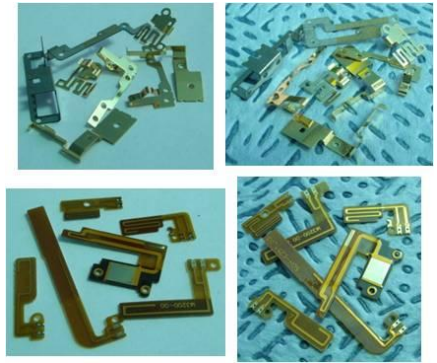

### Feature & Specification

- High efficiency on the limited space
- Higher freedom of a mounting space
- Highest design flexibility

Type	Model	Size [mm]	Frequency [GHz]	VSWR	Impedance	Beam Pattern
	FPCB type	21.4x5.8x0.25	2.4~2.485	2.5 : 1 max.	50 Ω	Omni-directional

Note: Customized design required

### Application

- Bluetooth Device : Headset, USB Dongle, PDA, Lap Top etc
- Zigbee module / Device
- Mobile Phone
- Various Wireless Devices
  - WLAN(IEEE802.11b &g)
  - WiBro(2.35GHz)
  - WiMax(2.5GHz)
  - S-DMB(2.64GHz)

# 2.4GHz wireless Communication

## PiFA Structure metal chip type

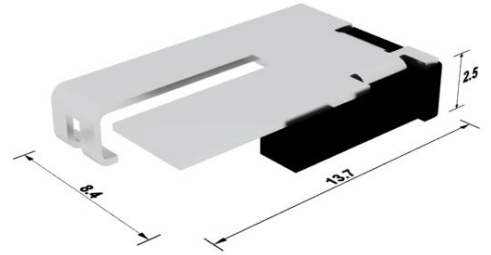

### Feature & Specification

- PIFA structure
- Able to optimized for on-ground condition
- Performance Optimizing with tuning the conductive pattern
- SMT available

Part No	Size	Frequency (MHz)	VSWR	Peak gain (dB)	Efficiency % @Avg
AMO-AF	13.7 x 8.4 x 2.5	2.4GHz ~2.485GHz	2.5 : 1 max	0.9 at azimuth 3.4 at elevation 1 5.0 at elevation 2	70%

Note: Customized design required

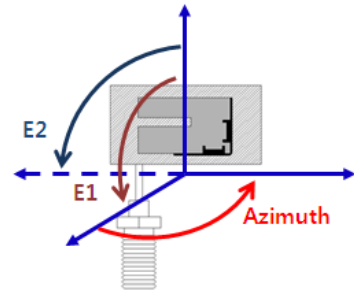
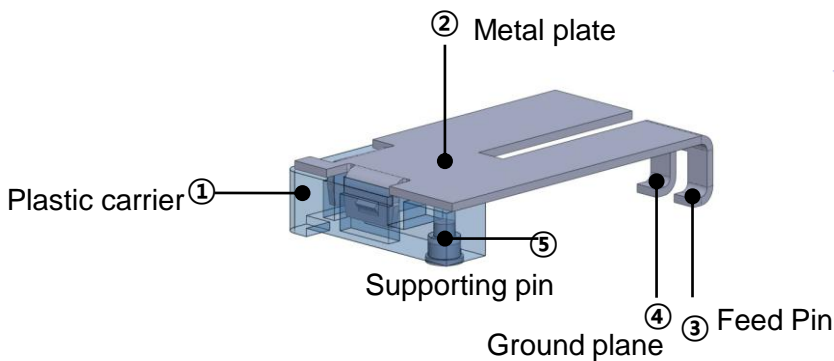

### Application

- Bluetooth
- Zigbee
- WLAN (IEEE 802.11 b/g)
- ISM 2.4GHz Wireless Devices

# ISM Band

## 315MHz-915MHz

### Chip Type (SMT)

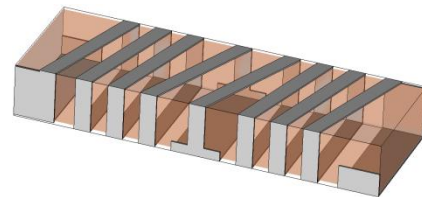

## Feature & Specification

- High efficiency on the limited space
- Higher freedom of a mounting space
- Highest design flexibility

Part No	Size (mm)	Frequency (MHz)	VSWR	Gain (dBi)
AMAM903012ST05	9.0x3.0x1.2mm	434~915	2.0:1max	-8dBi min @434MHz -7dBi min@868MHz -4dBi min@915MHz
AMAN120502ST01	12x5.0x2.0	315~433	2.0x1:max	-6dBi min@315MHz -6dBi min@433MHz

### Note

- 1) Impedance matching at 50ohm
- 2) Customized design support

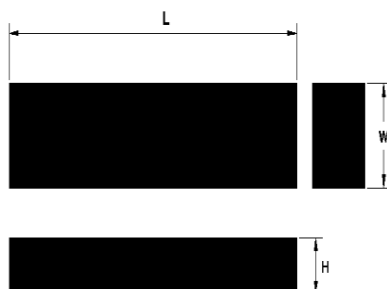

Unit : mm  
Tolerance : ±0.15

L(Length)	9.0
W(Width)	3.0
H(Height)	1.2

# ISM Band

## 433MHz

### Chip Type (SMT)

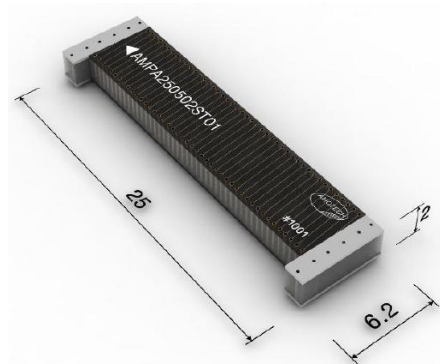

## Feature & Specification

- Helical Structure
- Easy Optimizing with external lumped matching components

Part No	Size (mm <sup>3</sup> )	Frequency (MHz)	VSWR	Gain (dBi)
AMPA250502ST01	25x5.0x2.0	433 MHz	2.0:1max	-4.6 dBi Avg -1.3dBi peak

Note: Tuning process required on customer's set

## PCB Design

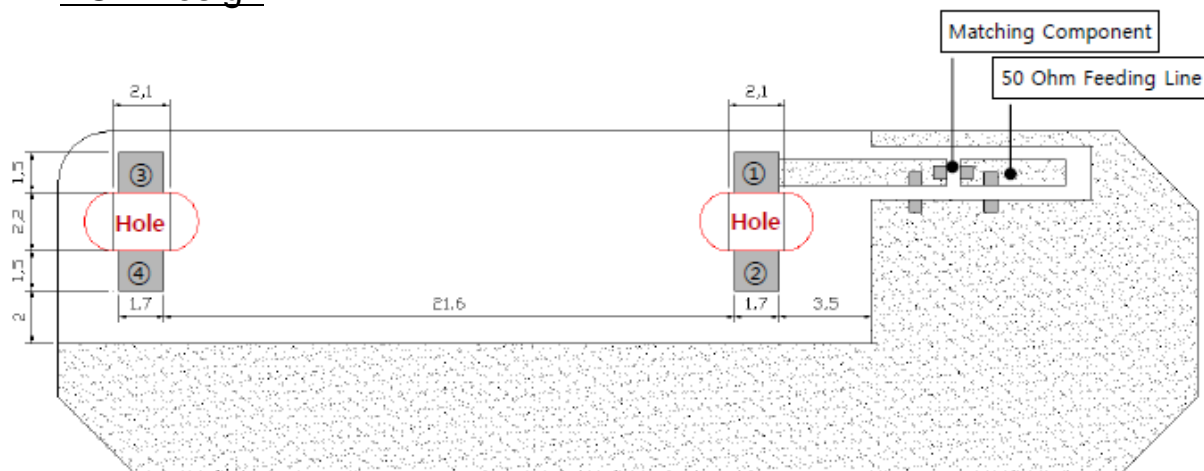

# ISM Band

## 900/915MHz

### Monopole Structure with cable



## Feature & Specification

- PCB & Monopole Structure
- Small form factor
- Adhesive tape for easy mounting

Part No	Size (mm <sup>3</sup> )	Frequency (MHz)	VSWR	Gain (dBi)
AMMAS001	34x7.0x0.75	902-928	Max 3:1	1.5min – 2.0 max 60% max efficiency

Note: Measure VSWR at Amotech Test Unit

## Mechanical Specifications

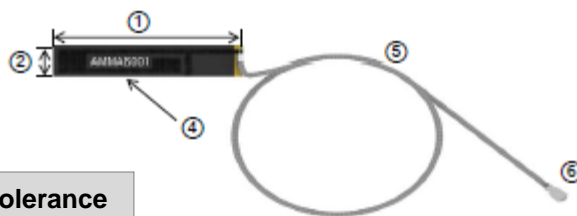

No.	Name	Dimension	Tolerance
①	Antenna Length	34.0mm	+/-0.5mm
②	Antenna Height	7.0mm	+/-0.5mm
③	Antenna Thickness	0.75mm	+/-0.03mm
④	PCB		Radiator

No.	Name		Function
⑤	RF Cable Length	100+/-3mm	
	RF Cable O/D	1.13+/-0.2mm	
⑥	Cable/ Connector	Hirose U.FL series	Technova Compatible (7000AC-000-1R0)

# Cellular Band

## On board chip type

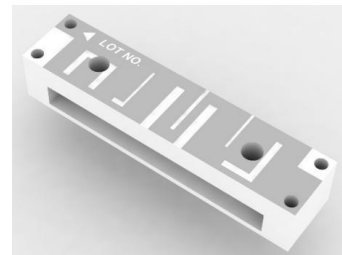

### Feature & Specification

- Small size
- High efficiency on the limited space
- Higher freedom of a mounting space
- Highest design flexibility

Part No	Size (mm)	Frequency (MHz)	VSWR	Peak Gain (dBi)	Efficiency % @min
AMMAQ002 (Right Feed)	22.0x5.5x4.4	880~960 1710~1850 1850~1990 1920~2170	3.5:1max	1.9dBi 4.3dBi 5.0dBi 4.9dBi	46.8% 62.8% 65.3% 74.0%
AMMAP004 (Left Feed)	24.0x5.5x4.4	824~894 880~960 1710~1880 1850~1990 1920~2170	3:5:1max	0.7dBi 0.7dBi 5.7dBi 4.8dBi 4.6dBi	45.0% 50.1% 73.5% 84.0% 87.7%
AMMAP003 (Right Feed)	24.0x5.5x4.4	824~894 880~960 1710~1880 1850~1990 1920~2170	3.5:1 max	1.3dBi 2.4dBi 6.4dBi 5.9dBi 4.8dBi	42.4% 57.3% 80.7% 84.0% 82.1%

#### Note

- 1) Impedance matching at 50ohm
- 2) Customized design support
- 3) EV Board size is 114 by 45mm

### Applications

- Automotive Tracking & Tracing
- Personal Tracking & Tracing

# Cellular Band

## PCB type Dipole antenna with cable

### Feature & Specification

- Dipole Structure
- Small form factor
- Adhesive tape for easy mounting

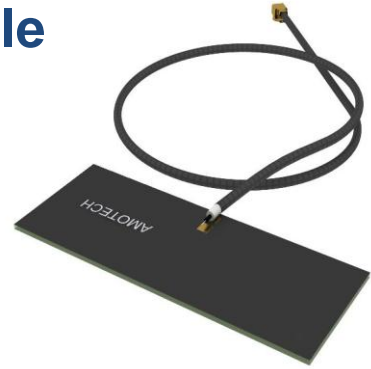

Part No	Frequency (MHz)	VSWR	Gain (dBi)	Efficiency % @min
AMMAP007	824~960MHz 1710~2170MHz	4.0:1 max 3.0:1 max	4.45 max-1.81min 4.40 max- 0.9 min	70 max-50min 90 max-50min

### Mechanical Specifications

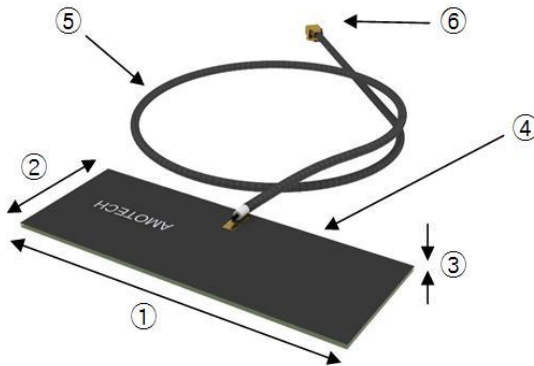

No.	Name	Dimension	Tolerance
①	Antenna Length	40.0 mm	±0.5
②	Antenna Height	15.0 mm	±0.5
③	Antenna Thickness	0.70 mm	±0.2

No.	Name	
④	PCB	Size
⑤	RF cable Length	200±5 mm
	RF cable O/D	1.13±0.2 mm
⑥	Cable connector	Hirose U.FL series

### Application

- Smart Meter
- WWAN Antenna / GSM 850 900/ DCS 1800/ PCS 1900/WCDMA

# Cellular Band

## FPCB type Dipole antenna with cable

### Feature & Specification

- Dipole Structure
- Small form factor
- Adhesive tape for easy mounting

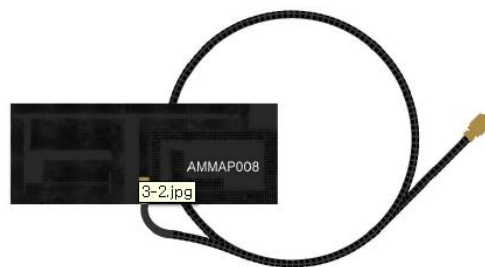

Part No	Frequency (MHz)	VSWR	Gain (dBi)	Efficiency % @min
AMMAP008	824~960MHz 1710~2170MHz	3.0:1 max 3.0:1 max	3.62 max-1.67min 5.25 max- 2.56min	70 max-50min 85 max-50min

### Mechanical Specifications

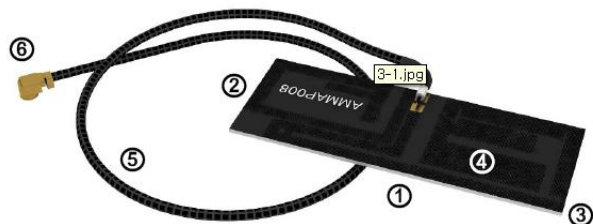

No.	Name	Dimension	Tolerance
①	Antenna Length	40.0 mm	±0.5
②	Antenna Height	15.0 mm	±0.5
③	Antenna Thickness	0.24 mm	±0.02

No.	Name	
④	PCB	Size
⑤	RF cable Length	200±5 mm
	RF cable O/D	1.13±0.2 mm
⑥	Cable connector	Hirose U.FL series

### Application

- Smart Meter
- WWAN Antenna / GSM 850 900/ DCS 1800/ PCS 1900/WCDMA

# Cellular Band

## PCB type Dipole antenna with cable

### Feature & Specification

- Dipole Structure
- Small form factor
- Adhesive tape for easy mounting



Part No	Frequency (MHz)	VSWR	Gain (dBi)	Efficiency % @min
AMMAP010	824~960MHz 1710~2170MHz	3.0:1 max 3.0:1 max	3.22 max-1.52min 5.78 max- 3.86min	70 max-50min 80 max-50min

### Mechanical Specifications

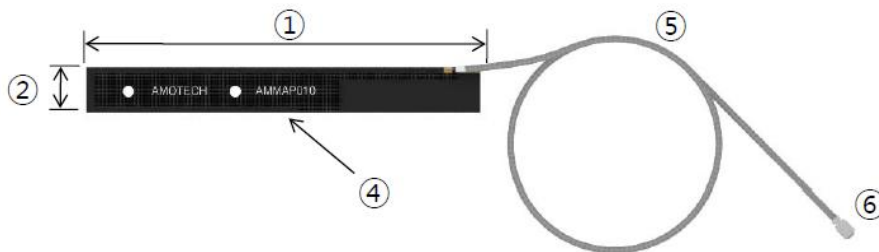

No.	Name	Dimension	Tolerance
①	Antenna Length	70.0 mm	±0.5
②	Antenna Height	8.0 mm	±0.5
③	Antenna Thickness	0.75 mm	±0.03

No.	Name	
④	PCB	Size
⑤	RF cable Length	150±3 mm
	RF cable O/D	1.13±0.2 mm
⑥	Cable connector	Hirose U.FL series

### Application

- Smart Meter
- WWAN Antenna / GSM 850 900/ DCS 1800/ PCS 1900/WCDMA

# Cellular Band

## PiFA structure with cable

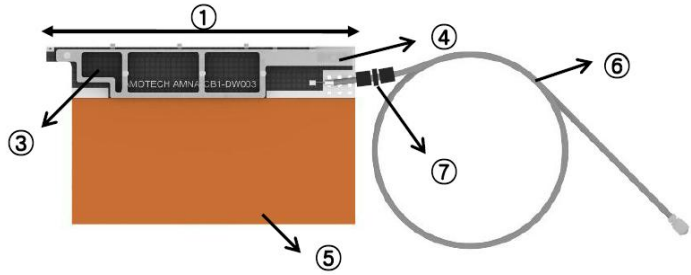

### Feature & Specification

- PiFA structure Quad band
- low profile

Part No	Size (mm)	Frequency (MHz)	VSWR	Gain (dBi)
AMNA-CB1-DW007	60x50x4.1	824~960 1710~1990	5.0:1 max 5.0:1 max	4.03 max 4.20 max

Note: Customized design required

### Application

- Lap Top
- E-book
- Net book

### Antenna Position



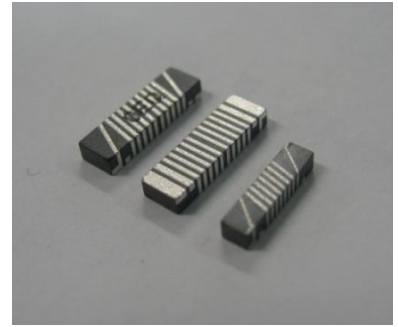

# FM Antenna

## Ferrite chip type



### Feature & Specification

- Small size
- SMD
- Wide bandwidth
- High efficiency

Type	Part No.	Size [mm]	Frequency [MHz]	VSWR	Impedance	Beam Pattern
	AMFA802015V1	8.0x2.0x1.5	87.5~108	6.0 : 1 max.	50 Ω	Omni-directional
	AMFA1003015V1	10.0x3.0x1.5	87.5~108	6.0 : 1 max.	50 Ω	Omni-directional
	AMFA1205020V1	12.0x5.0x2.0	87.5~108	6.0 : 1 max.	50 Ω	Omni-directional

#### Note

- 1) Impedance matching at 50ohm
- 2) Tuning support



# FM Antenna

## PCB chip type



### Feature & Specification

- Small Size, Low Cost
- Shorten the term of design
- Easy Mass Production
- Easy to SMT

Type	Part No.	Size [mm]	Frequency [MHz]	VSWR	Impedance	Beam Pattern
	AMFA2505008P1	25.0x5.0x0.8	87.5~108	6.0 : 1 max.	50 Ω	Omni-directional

#### Note

- 1) Impedance matching at 50ohm
- 2) Tuning support



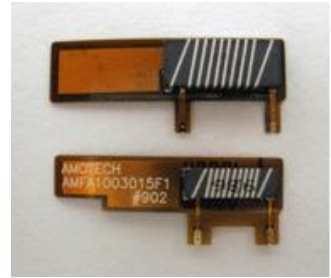

# FM Antenna

## FPCB type



### Feature & Specification

- High performance
- Customized design

Type	Part No.	Size [mm]	Frequency [MHz]	VSWR	Impedance	Beam Pattern
	AMFA1003015F1	25.5x9.5x1.8	87.5~108	6.0 : 1 max	50 $\Omega$	Omni-directional
	AMFA1205020F1	27.5x11.5x2.3	87.5~108	6.0 : 1 max	50 $\Omega$	Omni-directional

#### Note

- 1) Impedance matching at 50ohm
- 2) Tuning support

### Application

- FM radio broadcasting
- FM transmitter
- RDS-TMS

